

INSTRUCTION MANUAL

SG71 Strain Gage Amplifier Module



8626 Wilbur Avenue
Northridge, California 91324-4498
(818) 886-2057 • Telex 65-1303
TOLL FREE (800) 423-5851 (AK/CA use (818) number)
AUTOMATIC FAX (818) 886-6512

TABLE OF CONTENTS

Section 1

Description

1.1	INTRODUCTION	1-1
1.2	DESCRIPTION	1-1
1.3	TECHNICAL CHARACTERISTICS	1-1

Section 2

Installation and Operation

2.1	INSTALLATION	2-1
2.1.1	Input/Output Connections	2-1
2.1.2	Grounding	2-1
2.2	OPERATION	2-4
2.2.1	Strain Gage Fundamentals	2-4
2.3	SENSOR BRIDGE CIRCUITRY AND RESISTOR SELECTION	2-4
2.3.1	$\frac{1}{4}$ Bridge, 2-Wire Strain Gage	2-4
2.3.2	$\frac{1}{4}$ Bridge, 3-Wire Strain Gage	2-5
2.3.3	$\frac{1}{2}$ Bridge, 3-Wire Strain Gage	2-5
2.3.4	Shunt Calibration	2-5
2.3.5	Plus (+) Shunt Calibration	2-5
2.3.6	Minus (-) Shunt Calibration	2-5
2.3.7	Resistor Specifications	2-5
2.4	CALIBRATION SWITCH AND RESISTOR SELECTION	2-5
2.4.1	CAL 1	2-6
2.4.2	CAL 2	2-6
2.4.3	Resistor Selection	2-7
2.4.4	Resistor Specifications	2-7
2.5	BRIDGE BALANCE AND RESISTOR SELECTION	2-8
2.5.1	Resistor Selection	2-8
2.5.2	Resistor Specifications	2-8
2.6	DUAL OUTPUT	2-8
2.7	GAIN SWITCH AND VERNIER GAIN CONTROL	2-9
2.8	OSCILLOGRAPH GALVANOMETER OPERATION (OUTPUT B)	2-9
2.8.1	Resistor Selection and Installation	2-9
2.8.2	Resistor Specifications	2-11
2.9	SYSTEM CALIBRATION	2-11

Section 3

Theory of Operation

3.1	THEORY OF OPERATION	3-1
-----	---------------------------	-----

Section 4

Maintenance and Repair

4.1	INTRODUCTION	4.1
4.2	FACTORY REPAIR SERVICE	4.1
4.3	FIELD SERVICING HINTS	4.1

List of Illustrations

Figure 1-1.	SG71 Front Panel and Component Layout	1-2
Figure 2-1.	Wiring Configuration	2-2
Figure 2-2.	Full 4-Active Element Bridge	2-3
Figure 2-3.	¼ Bridge, 2-Wires	2-3
Figure 2-4.	¼ Bridge, 3-Wires	2-3
Figure 2-5.	½ Bridge, 3-Wires	2-3
Figure 2-6.	Shunt Calibration	2-6
Figure 2-7.	Plus (+) and Minus (-) Shunt Calibration 3-Wire, ¼ Bridge	2-7
Figure 2-8.	Procedure for Setting Gain Control	2-10
Figure 3-1.	SG71 Functional Block Diagram	3-2
Figure 4-1.	Bifurcated Terminal	4-2
Figure 4-2.	Strain Gage Amplifier Schematic	4-2

List of Tables

Table 1-1.	Technical Characteristics	1-3
Table 2-1.	Input/Output Pin Assignments	2-1

SECTION 1 DESCRIPTION

1.1 INTRODUCTION

This technical manual contains installation and operating instructions for the Model SG71 Strain Gage Amplifier. The SG71 is a plug-in module for a multi-channel transducer instrumentation system. The SG71 is manufactured by Validyne Engineering Corporation, Northridge, CA.

1.2 DESCRIPTION

The Model SG71 (see Figure 1-1) is a high gain, dual output, strain gage signal conditioner and power supply. The plug-in module is designed for use with Validyne's MC1 family of module cases.

Offering high frequency response, the SG71 supplies buffered, short-circuit proof, 5V DC excitation for the strain gage. Output from the external primary transducer is amplified to provide a standard $\pm 10V$ DC signal (output A) for input to recorders, meters, or data acquisition systems. The dual output SG71 provides a second, independent power circuit (output B) to drive galvanometers for oscillographic recording.

The SG71 accepts input from strain gages with bridge sensitivity ranging from 1 to 50 mV/V. A six-position gain switch on the front panel selects input sensitivity. A 10-turn gain vernier potentiometer on the front panel attenuates the gain within the gain step, from 0 to 100%.

Output B (for input to galvanometers) may be independently varied 20 to 100% of full scale: a screwdriver adjustment on the front panel provides control. Inside the SG71, terminals are provided for mounting resistors to match galvanometer damping requirements.

The Model SG71 accepts input from strain gage bridges with 1, 2, 3, or 4 active elements. For strain gages with fewer than 4 active elements, terminals are provided inside the module for mounting resistors to complete the bridge.

Any residual unbalance in the resistive bridge is corrected with a shunt, bridge balance control. This screwdriver adjustment is mounted on the front panel. The range of this bridge balance control can be extended or restricted by changing a series resistor inside the SG71.

Two test points and a momentary, three-position toggle switch on the front panel provide simple shunt calibration. Terminals inside the SG71 are provided for mounting precision shunt calibration resistors. The resistors are installed to establish either plus (+) or minus (-) levels for each calibration point.

All power requirements for the SG71 are supplied by the MC1 module case.

1.3 TECHNICAL CHARACTERISTICS

The technical characteristics of the SG71 are listed in Table 1-1.

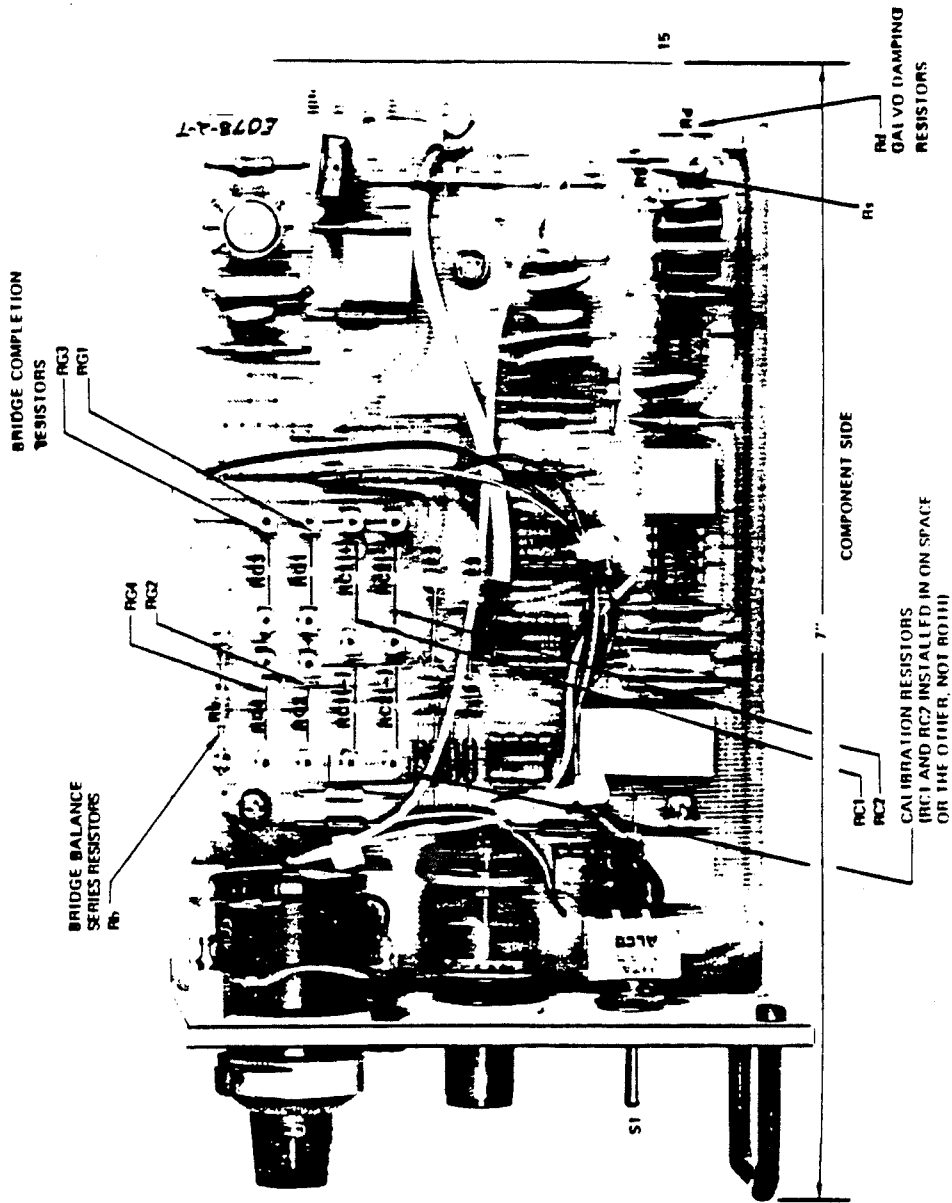
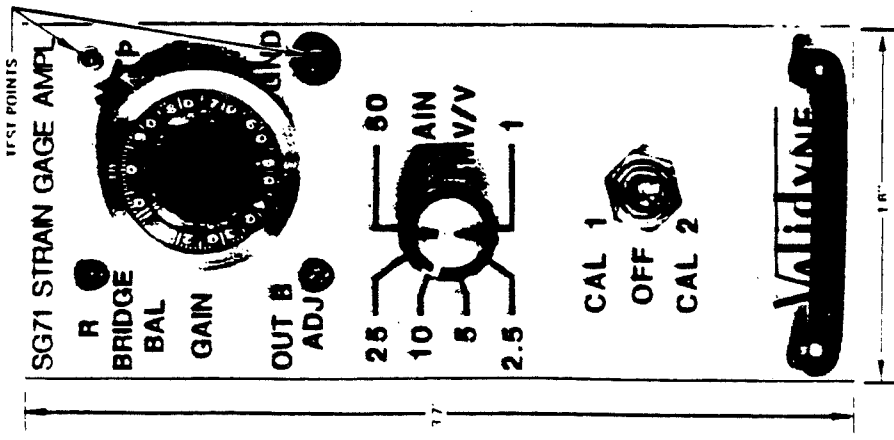

Figure 1-1. SG71 Front Panel and Component Layout

TABLE 1-1. TECHNICAL CHARACTERISTICS

ELECTRICAL	
Input Sensitivity for 10V DC Output	1, 2.5, 5, 10, 25, or 50 mV/V; switch selected
Gain Vernier	0-100%, 10-turn precision potentiometer with calibrated dial
Bridge Excitation	5V DC, 50 mA maximum; minus (-) side connected to circuit ground; protected against short circuits
Bridge Configuration	100 ohm minimum; 1, 2, 3, or 4 active elements Terminals are provided for up to 4 resistors to complete the bridge
Input Impedance	Greater than 10 megohms
Bridge Balance	Shunt type, 15-turn screwdriver adjust for ± 1.7 mV/V with 350 ohm bridge Balance control range can be field selected with internal series resistor
Output Voltage	Both outputs are controlled by gain switch and vernier
Output A	± 10 V DC, 10 mA maximum
Output B	± 100 mA maximum, into 50 ohm load; 10V DC open circuit
Output B Adjustment	15-turn, screwdriver adjust for 20-100% of output
Output Impedance	
Output A	Less than 10 ohm
Output B	Nominally 50 ohm; can be selected in the field for optimum galvo damping
Output Noise	20 mV RMS @ 10V DC, @ 1 mV/V sensitivity
Frequency Response	0-10 kHz, flat $\pm 5\%$
Linearity	$\pm 0.05\%$ (best straight line), up to ± 10 V DC output Maximum ± 1 V DC input for linear output
Common Mode Rejection	80 dB @ 60 and 120 Hz
Maximum Common Mode Voltage	± 10 V DC
Common Mode Input Impedance	Greater than 100 megohm
Temperature Range	0°F to +160°F
Thermal Zero Shift	0.02%/°F @ maximum gain (1 mV/V)
Thermal Sensitivity Shift	0.005%/°F
Power	± 15 V DC (supplied from MC1 module case)
FRONT PANEL CONTROLS	6-position, rotary Gain Select switch
(See Figure 1-1 for location)	10-turn, calibrated dial Gain Vernier Control potentiometer 15-turn, screwdriver adjust Bridge Balance Control ("R") Two pin-plug Test Point jacks, Output A and Ground

TABLE 1-1. TECHNICAL CHARACTERISTICS (Cont'd)

MECHANICAL	
Dimensions	
Width	1.6 inches
Height	3.7 inches
Depth	7.0 inches
Weight	Less than 7 oz
Connections	
	Plugs into Validyne MC1 Series module case
Input Connections	Through Cannon WK-4-32S connector
Output Connections	Through Cannon XLR-3-32S (or equivalent) (except MC-1) (Note: Input and output connectors located on rear panel of MC1 Module Case)
Mating Connectors	
	Input: Cannon WK-4-21C Output: Cannon XLR-3-11C

SECTION II INSTALLATION AND OPERATION

2.1 INSTALLATION

The Model SG71 may be plugged in or out of any available channel of the MC1 module case while power is on. No damage will occur, and adjacent channels are not affected.

2.1.1 Input/Output Connections

The strain gage bridge is connected to the SG71 via the WK-4-32S receptacle marked "Transducer Input" on the back panel of the MC1 module case. Table 2-1 illustrates the pin assignments. The mating connector is WK-4-21C.

SG71 output is available at two separate XLR-3-32S connectors marked "Output A" and "Output B" on the back panel of the MC1 module case. Pin assignments are the same for both receptacles. (See Table 2-1.)

2.1.2 Grounding

For proper grounding, cable shields must be connected to the shells of the mating connectors.

Figure 2-1 identifies the edge connector pads on the SG71 printed circuit board. Figure 2-1 also identifies pin assignments for the mating 15-pin edge connector inside the MC1 module case.

Figures 2-2 through 2-5 show several ways to connect strain gage transducers with 1, 2, 3, or 4 active elements to the MC1 input connector.

TABLE 2-1. INPUT/OUTPUT PIN ASSIGNMENTS

Pin No.	Function
MC1 INPUT CONNECTIONS (WK4)	
1	(+) bridge excitation
2	(+) bridge output
3	(-) bridge output
4	bridge excitation return (system ground)
MC1 OUTPUT CONNECTIONS (XLR)	
1	Output
2	Circuit Ground
3	Chassis Ground

NOTE: Pin connections are the same for both Output A and B

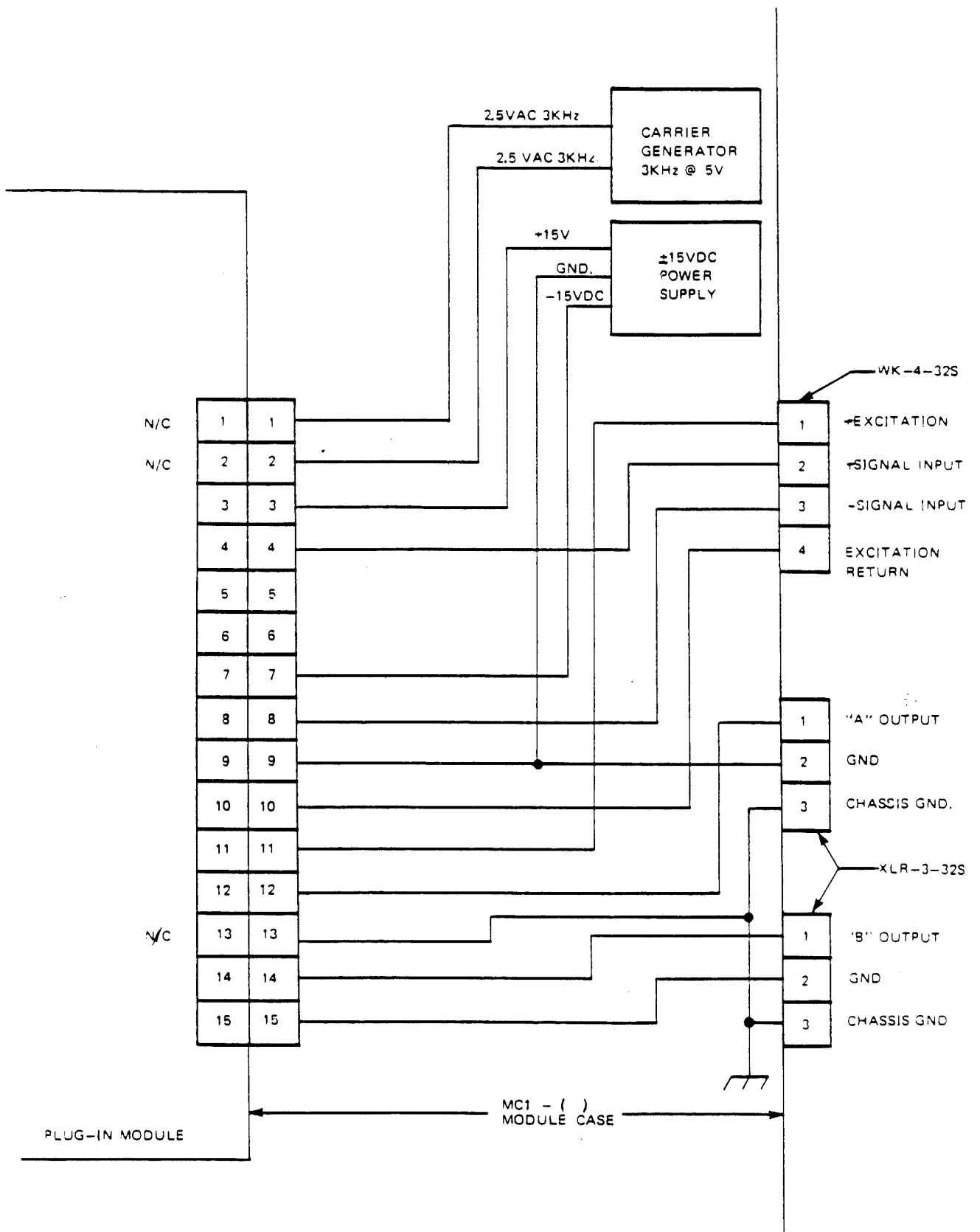

Figure 2-1. Wiring Configuration

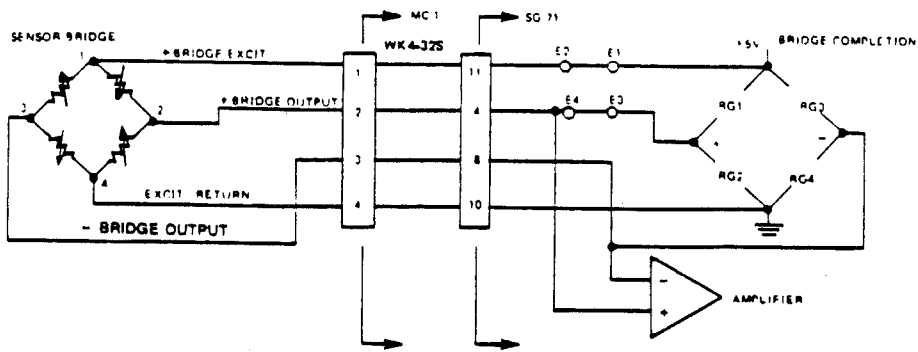

Figure 2-2. Full 4-Active Element Bridge

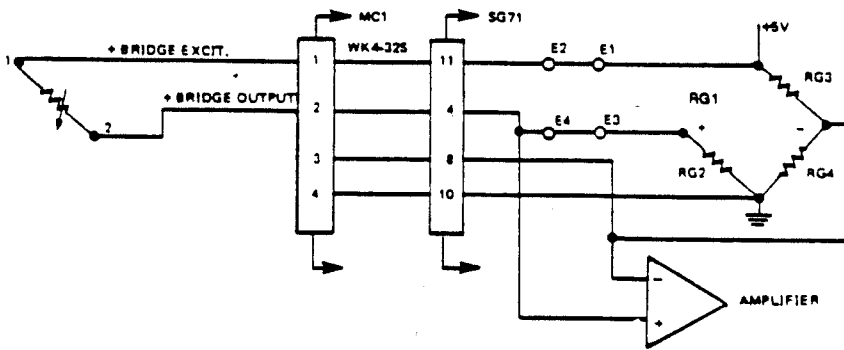

Figure 2-3. 1/4 Bridge, 2-Wires

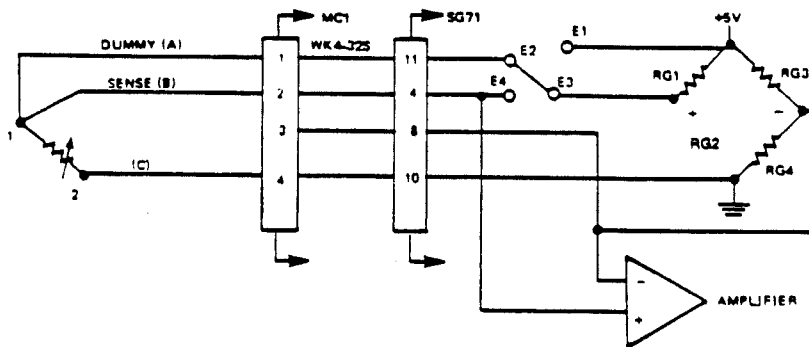

Figure 2-4. 1/4 Bridge, 3-Wires

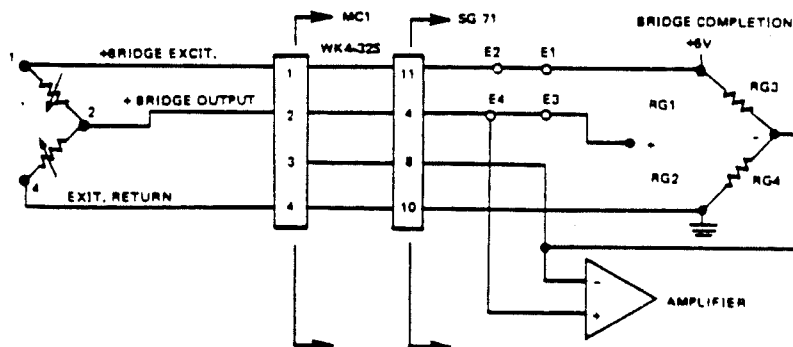

Figure 2-5. 1/2 Bridge, 3-Wires

2.2 OPERATION

See Figure 1-1 for location of SG71 controls and identification of components that can be selected in the field.

2.2.1 Strain Gage Fundamentals

A strain gage converts a small physical movement into proportional changes in electrical resistance. A strain gage is made by bonding fine wire to a supporting structure. In application, the support structure is stretched or compressed which results in a change in dimension.

When a specified excitation voltage is applied, the change in resistance of the strain gage produces from 1 to 3 mV to as much as 50 mV or more per excitation volt applied.

The change in resistance for a single strain gage element is very small. For this reason, many strain gages consist of four elements connected as a Wheatstone Bridge. Half the bridge is compressed while the other half is under tension, for a given amount of change in dimension, this bridge arrangement multiplies the change in resistance by four.

Typical impedance of a strain gage is 350 ohms.

Refer to Figure 2-2. Notice that a potentiometer-like symbol identifies the active strain gage element(s). The direction of the arrow indicates increasing or decreasing resistance, and it establishes a kind of "polarity" for the transducer.

NOTE

Strain gage "polarity" must be observed when connecting transducers to the SG71.

2.3 SENSOR BRIDGE CIRCUITRY AND RESISTOR SELECTION

Refer to Figures 2-2 through 2-5.

A strain gage bridge with 1, 2, 3, or 4 active elements can be connected to the SG71. To maintain proper input polarity, connect increasing resistance (tension) elements between Pins 1 and 3 and/or Pins 2 and 4 of the WK-4-32S input connector. Connect decreasing resistance (compression) elements between Pins 1 and 2 and/or Pins 3 and 4.

For four-element, full bridge operation, jumper E1 to E2 and jumper E3 to E4.

When connecting a sensor bridge with less than four active elements, the bridge must be completed inside the SG71. Install resistors equal to the resistance of the active element between the terminal points provided on the circuit board. One resistor is needed for each "missing" element of the bridge.

2.3.1 $\frac{1}{4}$ Bridge, 2-Wire Strain Gage

Figure 2-3 shows the configuration of a strain gage and resistors for completing a sensor bridge with only 1 active element.

NOTE

Any position may be used for the active element. Just observe output polarity with respect to the position of increasing and/or decreasing resistance(s).

2.3.2 ¼ Bridge, 3-Wire Strain Gage

A sensor bridge with 1 active element can also be connected to the SG71 with three wires for greater accuracy. Known as a 3-wire, ¼ bridge, this configuration is shown in Figure 2-4. For 3-wire, ¼ bridge operation, jumper E2 to E3. There is *no connection* from E1 to E2.

A careful look at the 2-wire configuration shows that both leads to the external active element are in the same half of the bridge. Long lead length, and temperature changes will vary the resistance, sensitivity, balance, and accuracy of the 2-wire, ¼ bridge.

In the 3-wire configuration, one lead wire (plus (+) bridge excitation) is in series with the active gage element. A second wire (excitation return) is in series with the dummy leg. The third wire is *not* part of the bridge; it carries no bridge current and acts only to sense the output voltage from the dummy half of the bridge.

If wires (A) and (C) are equal in resistance (length), then they will have no effect on the Zero Balance of the bridge — regardless of lead length or temperature changes.

2.3.3 ½ Bridge, 3-Wire Strain Gage

Figure 2-5 shows the configuration of a strain gage and resistors for completing a sensor bridge with two active elements. For two-element, ½ bridge operation jumper E1 to E2 and E3 to E4.

2.3.4 Shunt Calibration

With a full bridge sensor, the resistance of opposing elements is theoretically equal, and the voltage across each half of the bridge is equal. This means that shunt calibration (with either plus (+) or minus (-) voltage) across any element will provide the same output. (See Figure 2-6.)

2.3.5 Plus (+) Shunt Calibration

In the 3-wire, ¼ bridge, one cable lead is put in series with the active element. The other cable resistance is in series with a dummy element of the bridge.

This means that the relationship between ΔR in the active gage and positive (+) shunt calibration across the dummy element is independent of cable resistance or cable length. (See Figure 2-7.)

2.3.6 Minus (-) Shunt Calibration

NOT RECOMMENDED. Minus (-) shunt calibration with a ¼, 3-wire sensor places the calibration resistor across both the active gage and both of its cable resistances. Regardless of cable length, this technique will always produce shunt calibration errors. (See Figure 2-7.)

2.3.7 Resistor Specifications

Use only high quality resistors (0.1% or better) with a low temperature coefficient for completing the input bridge circuit.

2.4 CALIBRATION SWITCH AND RESISTOR SELECTION

The front panel Calibration Switch (a momentary, normally open, three-position toggle) selects one of two internal shunt calibration resistors. The terminals for mounting these resistors are arranged to establish two plus (+) calibration points, two minus (-) calibration points, or one plus (+) and one minus (-) calibration point. The test signals are available at Test Points on the front panel.

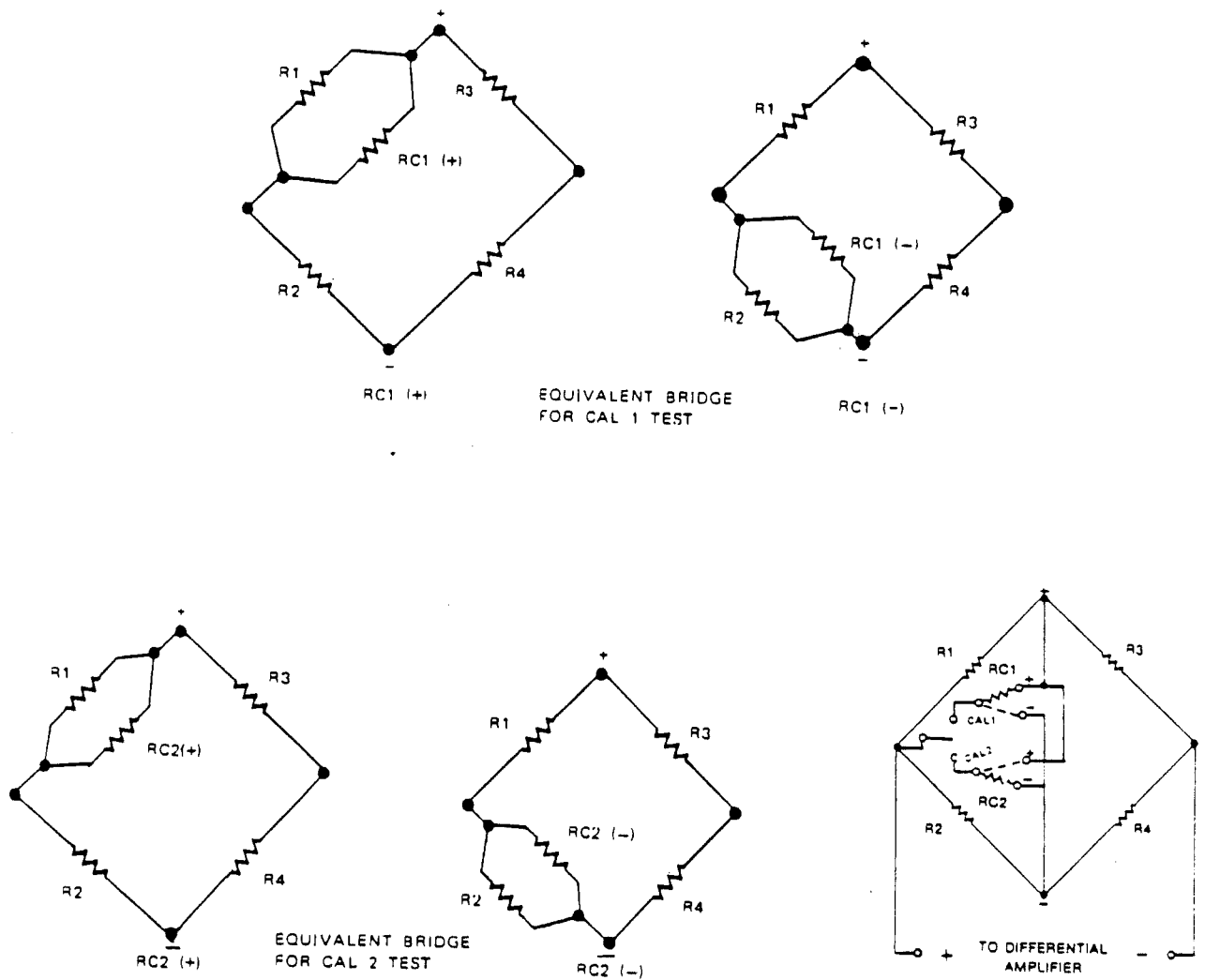

Figure 2-6. Shunt Calibration

2.4.1 CAL 1

See Figure 1-1. Connect resistor RC1 between the center and the plus (+) terminal to produce a positive signal simulating bridge output with the switch in the upper, CAL 1, position. Or, connect RC1 between the center and the minus (-) terminal for negative output at the Test Points when the switch is in the upper CAL 1 position.

2.4.2 CAL 2

See Figure 1-1. Connect resistor RC2 between the center and the plus (+) terminal to provide a positive signal simulating bridge output with the switch in the lower, CAL 2, position. Or, connect RC2 between the center and the minus (-) terminal for negative output at the Test Points when the switch is in the lower CAL 2 position.

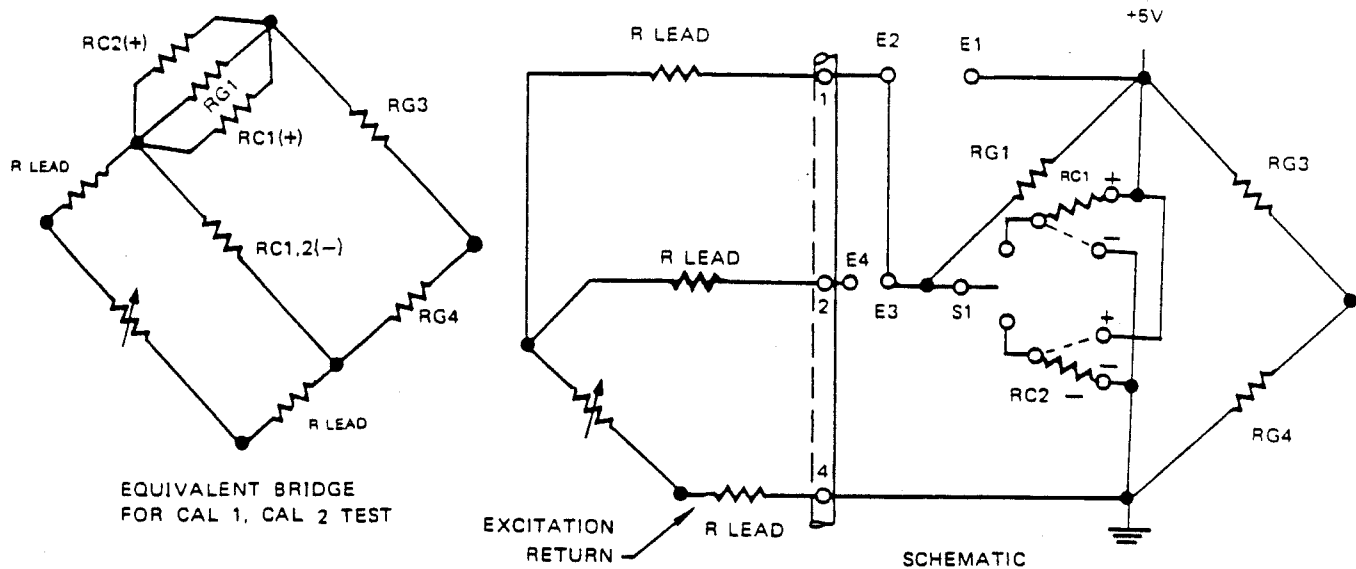

Figure 2-7. Plus (+) and Minus (-) Shunt Calibration 3-Wire, 1/4 Bridge

2.4.3 Resistor Selection

Use this formula to calculate the approximate values for calibration resistors RC1 and RC2:

$$RC = \frac{RB}{2} \left\{ \frac{10^3}{2ECAL} - 1 \right\}$$

where RC = calibration resistance RC1 or RC2 (in Ohms)

RB = bridge sensor resistance, four equal-arm bridge (in Ohms)

ECAL = desired calibration voltage sensitivity (in mV/V)

For example: 350 Ohm bridge; sensitivity = 1 mV/V

$$RC = \frac{350}{2} \left\{ \frac{1000}{2(1)} - 1 \right\}$$

$$= 175 (499)$$

$$= 87.325 \text{ Ohm}$$

2.4.4 Resistor Specifications

Use only high quality resistors (0.1% or better) with a low temperature coefficient for shunt calibration.

2.5 BRIDGE BALANCE AND RESISTOR SELECTION

To balance the bridge, connect a DC voltmeter to the front panel Test Points. Use the Gain Switch to select the correct sensitivity for the transducer in use. Turn the screwdriver adjust Balance Control for a minimum reading on the voltmeter.

If the Balance Control does not provide enough range, change the value of the bridge balance resistor, R_b. (See Figure 1-1.)

The value of R_b is usually 49.9K Ohm. This provides up to ±1.7 mV/V balance signal at the amplifier (with input from a 350 Ohm bridge) which is adequate for most applications.

NOTE

Check the condition of the sensor bridge and the values of the resistors used to complete the input bridge before altering R_b to make large changes in the balance signal.

2.5.1 Resistor Selection

A new value for the bridge balance resistor can be calculated with the same formula used to select calibration resistors. Just substitute "balance voltage" for "calibration voltage":

$$R_b = \frac{RB}{2} \left\{ \frac{10^3}{2EBAL} - 1 \right\}$$

where R_b = value of bridge balance resistor (in Ohms)

RB = bridge sensor resistance, four equal-arm bridge (in Ohms)

EBAL = desired balance voltage (in mV/V)

For example: 100 Ohm bridge; balance voltage = 4 mV/V

$$\begin{aligned} R_b &= \frac{100}{2} \left\{ \frac{1000}{2(4)} - 1 \right\} \\ &= 50 (124) \\ &= 6200 \text{ Ohm} \end{aligned}$$

2.5.2 Resistor Specifications

Use only high quality resistors (0.1% is acceptable) with a low temperature coefficient when field selecting the bridge balance voltage.

2.6 DUAL OUTPUT

The SG71 provides dual output. Output A is a standard 10V DC signal for input to recorders, meters and data acquisition systems. Output B is a 100 mA current signal for input to recording galvanometers.

Both output circuits are protected against short circuits. If a short occurs, the output amplifier of the SG71 automatically current limits. When the short is removed, the amplifier recovers immediately.

2.7 GAIN SWITCH AND VERNIER GAIN CONTROL

Both Output A and Output B are controlled with the front panel Gain Switch and Vernier Gain Control. With the 10-turn Vernier Gain Control fully clockwise (10 on the dial), the Gain Switch shows the input (in mV/V) needed to obtain a full scale (10V DC) output. The 10-turn Vernier Gain Control reduces the gain to accommodate input sensitivity between settings on the Gain Switch.

NOTE

The maximum input signal for a particular Gain Switch setting must not produce more than 10V DC output with a minimum Vernier Gain Control dial reading of 1.5. This corresponds to an input approximately 6.6 times that of the Gain Switch setting: 66 mV/V at the 10 mV/V setting; 330 mV/V at the 50 mV/V setting.

Figure 2-8 shows how to set the Vernier Gain Control.

NOTE

See Para. 2.9 for full-scale calibration as a system.

2.8 OSCILLOGRAPH GALVANOMETER OPERATION (OUTPUT B)

Output B will drive most commercially available galvanometers. The circuit provides 100 mA into a minimum load of 50 ohms. Open circuit voltage is 10V. Inside the SG71, terminals are provided for mounting damping resistors, R_s and R_d , for optimum galvanometer performance. (See Figure 1-1.)

A screwdriver adjustment on the front panel varies Output B 20 to 100% independently of the other gain controls. The Output B Adj is used to get the desired galvanometer deflection for any given input gain setting.

2.8.1 Resistor Selection and Installation

The R_s and R_d damping resistor terminals are arranged like this:

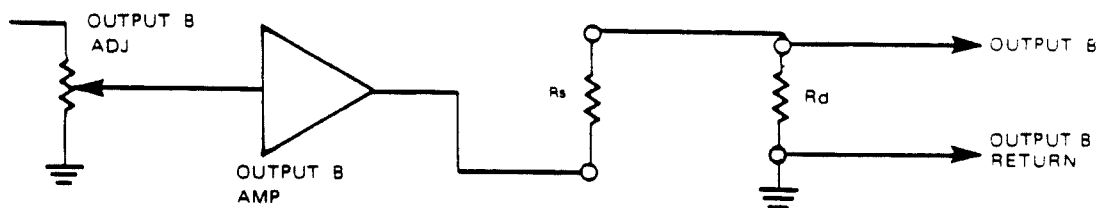

For all practical purposes, the output impedance of the amplifier is negligible. A resistor in the R_s terminals will provide damping for most high frequency, fluid-damped galvanometer applications. The value of R_s will be found in the galvo manufacturer's performance specifications.

To preserve the "short circuit safe" output rating of the B-output amplifier, the value of R_s should not be less than 50 Ohms. If a damping resistance less than 50 Ohms is required, calculate a value for R_d to obtain the correct damping.

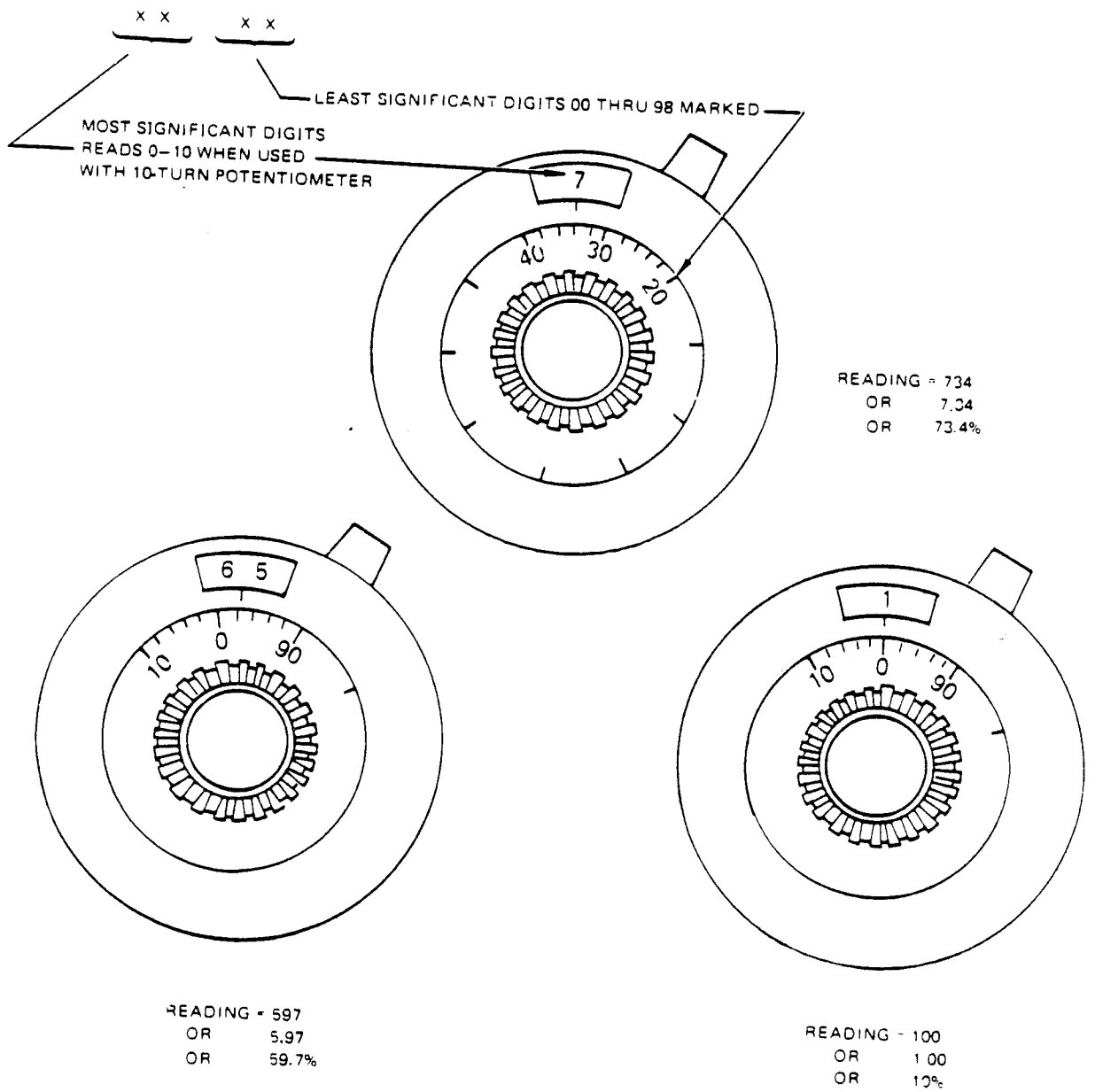

Figure 2-8. Procedure for Setting Gain Control

Use this formula to calculate R_d :

$$R_d = \frac{50 R_D}{50 - R_D}$$

where R_D = required galvo damping resistance

For low frequency, magnetically-damped galvanometers, a high source impedance (R_s = high value) is required for properly controlling galvo current and deflection.

With R_s = 100K ohm, the value of R_d will equal the required galvo damping resistance for all practical purposes. Thus R_s = 100K ohm, and R_d = manufacturer's specified galvo damping resistance.

NOTE

If the Output B Adj will not adequately control the deflection of a particular galvo, increase R_s to decrease deflection and decrease R_s to increase deflection. Doubling the value of R_s will decrease deflection by 50%; halving the value of R_s will increase deflection by 50%.

2.8.2 Resistor Specifications

Use only high quality resistors (high precision is not needed) with a low temperature coefficient when changing the galvo damping resistors. Use a power-type resistor for R_s if a short circuit load draws more than 25 mA. R_{36} must be 47 Ohms or greater to prevent component damage in the event of a short circuit load.

2.9 SYSTEM CALIBRATION

To calibrate the SG71 as a system:

- a. Plug the SG71 strain gage amplifier into any available channel of the MCI series module case.
- b. Connect the strain gage transducer and its cable to the channel with the SG71 module. Connections are made at the rear of the MCI series module case.
- c. Turn the MCI power supply on. The SG71 may be plugged into or out of the MCI case while the power is on with no harm or effect on any of the MCI modules.
- d. Select the appropriate mV/V gain setting for the transducer in use. (See Para. 2.7.)
- e. With zero pressure applied to the transducer monitor the DC output voltage with a DC voltmeter. Output "A" is available either at the front panel test point (TP & GND) or by removing the "A" output mating connector on the rear of the module case (pin 1 positive; pin 2 common).
- f. Adjust the "A" output to 0.00V DC by using the screwdriver adjustable R-bridge balance control.
- g. With the desired full scale pressure applied to the transducer adjust the (10 turn dial) gain control to set the "A" output to 10.00V DC. The "B" output may be set by the screwdriver adjustable "output B" control and monitoring the galvanometer deflection.
- h. The front panel calibration switch selects one of two internal shunt calibration resistors, as outlined in para. 2.4.

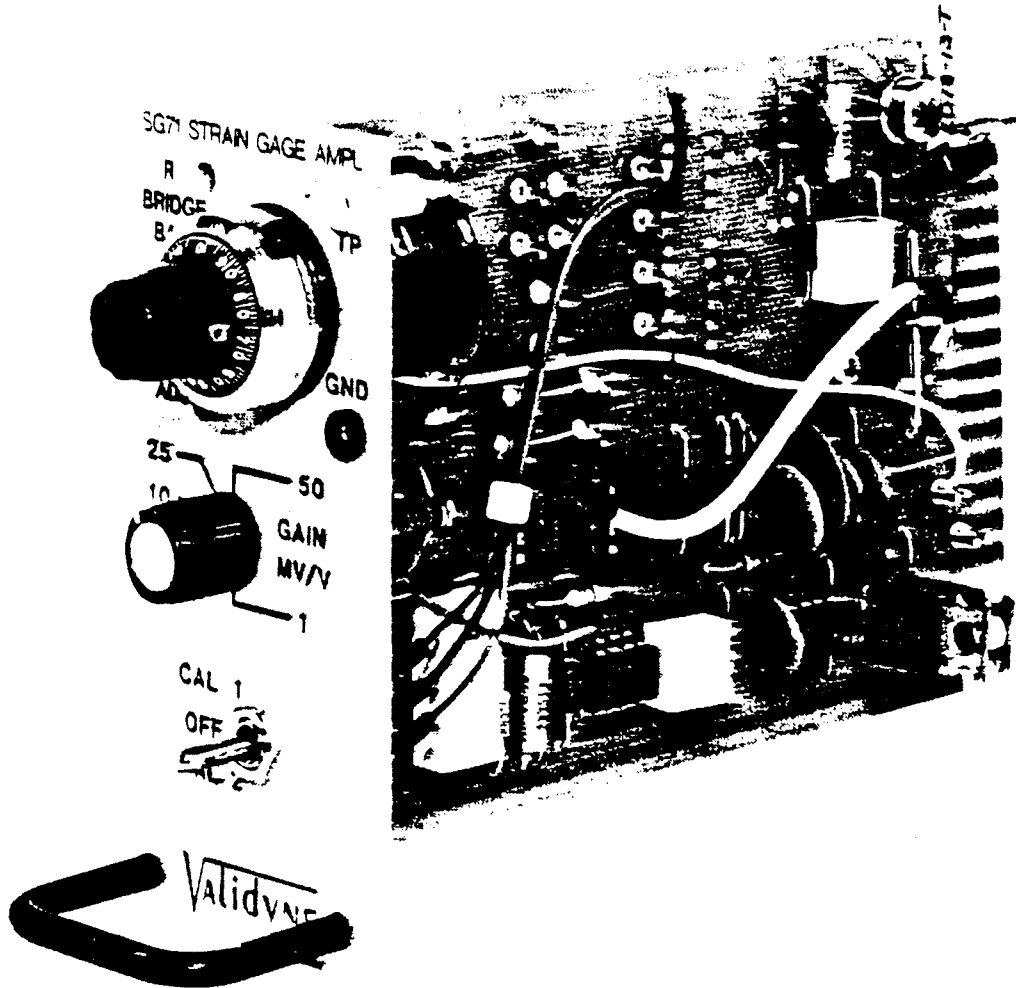

Model SG71 Strain Gage Amplifier

SECTION 3 THEORY OF OPERATION

3.1 THEORY OF OPERATION

Refer to Figure 3-1.

The external strain gage (1, 2, 3, or 4 active elements) is excited with 5V DC from the power supply regulator.

For sensor bridges with less than 4 active elements, the bridge is completed by mounting resistors RG1, RG2, RG3, and/or RG4 and connecting jumpers at E1, E2, E3, and/or E4 as required by the bridge configuration.

Output from the sensor bridge is applied to a high-gain differential amplifier. Any residual output from the transducer is nulled by summing a small portion of the excitation voltage. The bridge balance potentiometer, R38, picks off the appropriate voltage for input to the differential amplifier through isolation resistor Rb.

Input sensitivity is controlled by a six-position switch, S2, in the feedback loop of the input amplifier circuit. Output from the first differential amplifier is fed to a second differential amplifier, then through the vernier gain potentiometer, and finally to a buffer amplifier.

The buffer amplifier provides impedance isolation to unload the precision gain control potentiometer and maintain its linearity. As a result, numbers on the 10-turn dial have meaning as actual percentages of output.

Calibration points are established by electrically unbalancing the bridge with appropriate shunt resistors RC1 and RC2. Switch S1 selects two different calibration points, one at a time. RC1 and RC2 may be installed to establish two plus (+), two minus (-), or one plus (+) and one minus (-) calibration point.

A voltage amplifier provides 10V for Output A. A separate power amplifier circuit with its own output gain adjustment provides current for Output B.

The series-parallel combination of resistors Rs and Rd provide damping for a galvanometer connected to Output B. R36 (Rs) must be 47 Ohms or greater to prevent component damage in the event of a short circuit load.

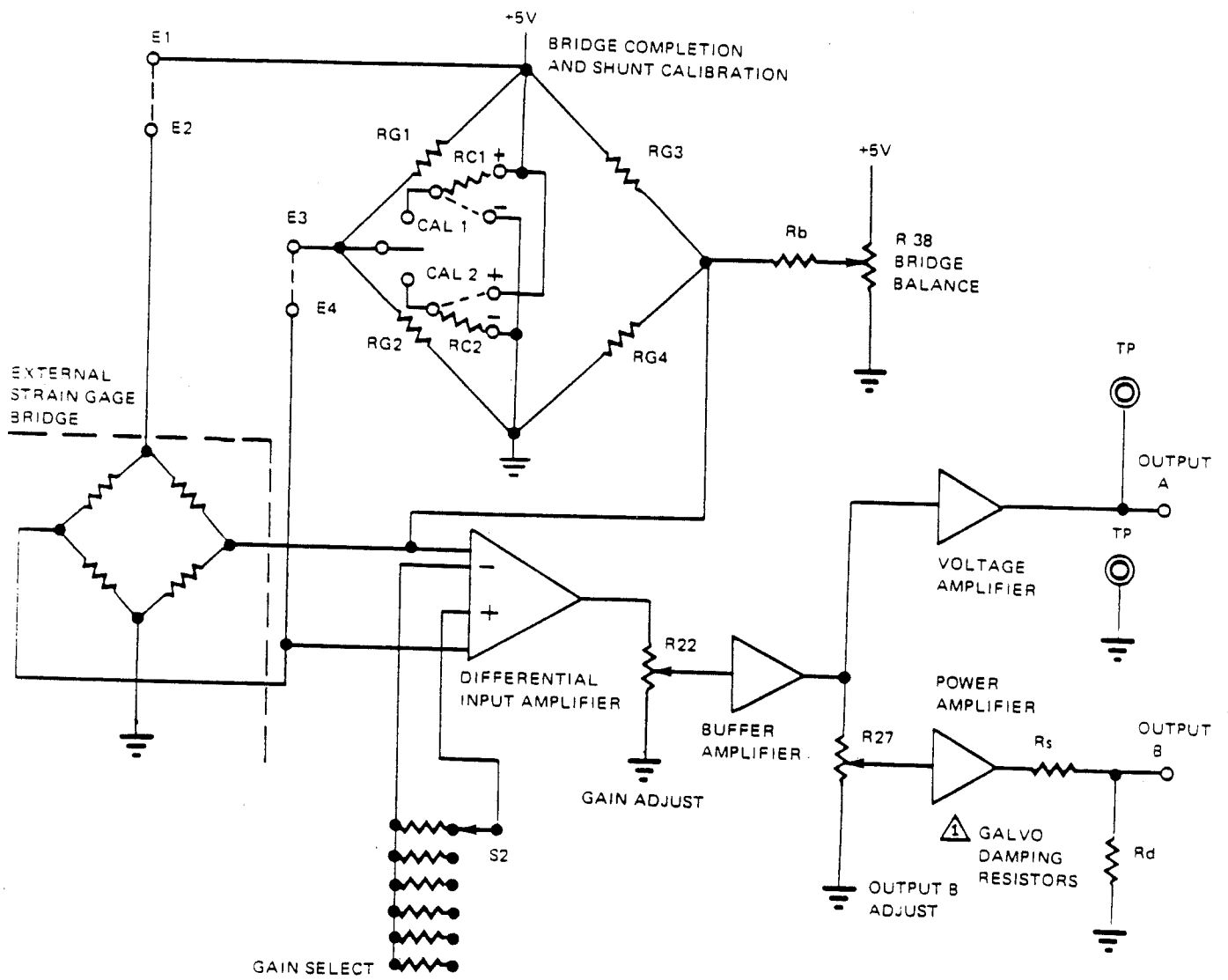

⚠️ RG1, RG2, RG3, RG4, R_s, R_d AND E1, E2, E3, E4
 JUMPER CONFIGURATION, CUSTOMER INSTALLED.

Figure 3-1. SG71 Functional Block Diagram

SECTION 4 MAINTENANCE AND REPAIR

4.1 INTRODUCTION

By design, Validyne products do not require periodic recalibration or other maintenance.

4.2 FACTORY REPAIR SERVICE

If abnormal performance cannot be corrected using the calibration and adjustment procedures outlined in this manual, return the unit to the factory for evaluation and repair. All repairs must be sent *transportation PREPAID*.

For the speediest reply, send a brief explanation of the malfunction. Also include purchase order number and date.

At your request, we will submit an estimate of costs before starting to repair the unit.

Mark all repair shipments and correspondence "ATTN: CUSTOMER RETURNS GROUP" and send to:

Validyne Engineering Corporation
8626 Wilbur Avenue
Northridge, CA 91324

4.3 FIELD SERVICING HINTS

Validyne plug-in modules are designed to simplify field servicing and component selection.

Special heavy-duty "bifurcated" terminals are provided for mounting calibration, bridge completion, and galvo damping resistors. (See Figure 4-1.)

These bifurcated terminals require no crimping or lead bending. Simply drop the component in place and solder. This speeds both installation and removal.

Figure 4-2 is a schematic diagram of the SG71 Strain Gage Amplifier.

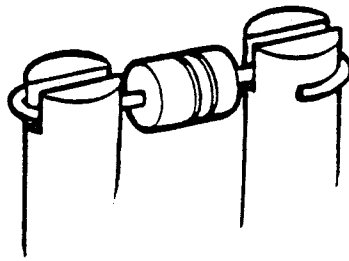

Figure 4-1. Bifurcated Terminal

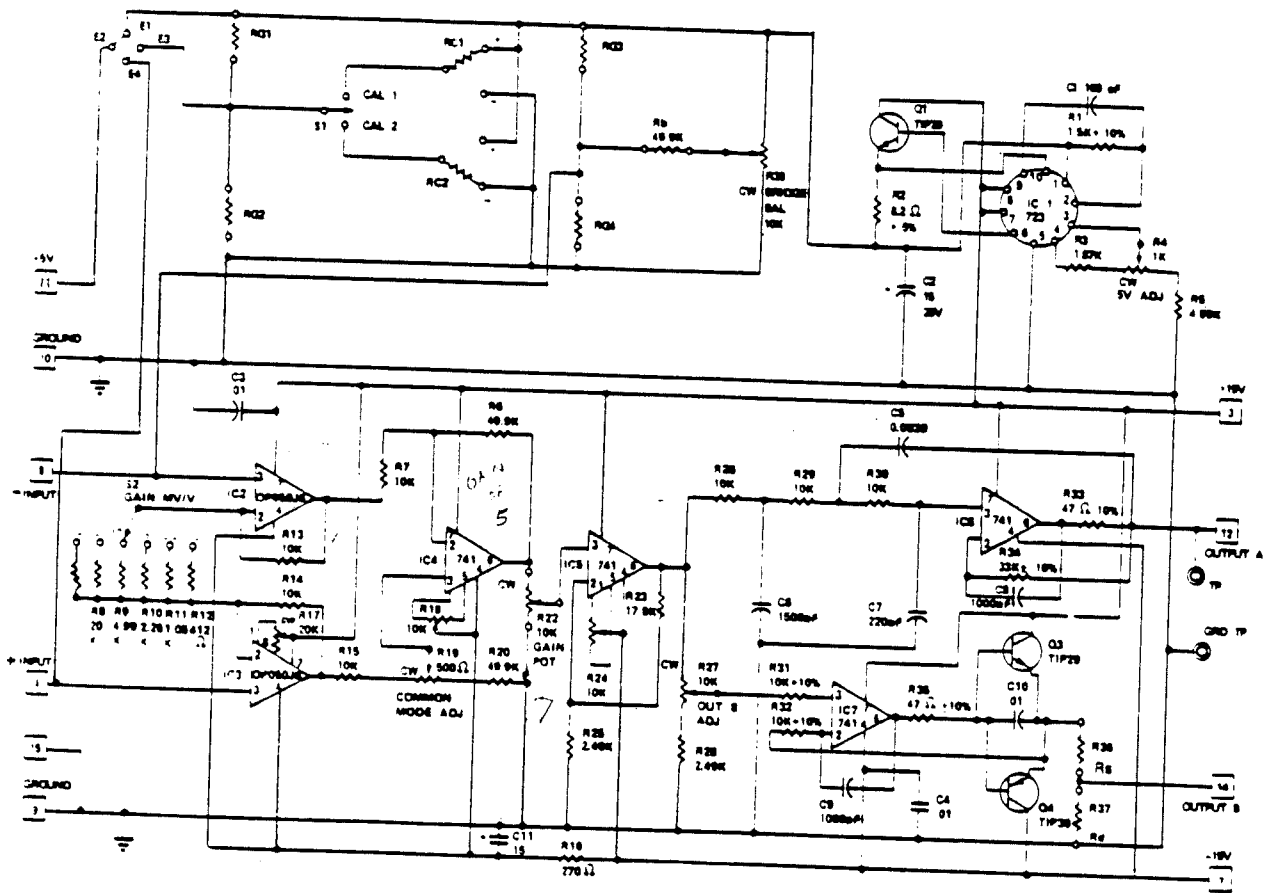

Figure 4-2. Strain Gage Amplifier Schematic



PCN NO. N/A

DATE October 24, 1991

SHEET 1 OF 1

PUBLICATION CHANGE NOTICE

This notice is issued to change or update this publication for Validyne Model MCI Plug in signal conditioners

For all instruments, make changes in this publication as listed below:

For instruments having model dash number _____ make the following publication changes:

This PCN is to add input and output connector information for the following MCI plug in signal conditioners:

BA112	AD136	CD148	NI167
LPF162	LPF167	CD18	CD19
PM204	BPF205	EC209	PM212
FC236	TC243	CD257	
AM49	PT60	FC62	AL64
SG71	PA89	CD90	PE251
TC453			

WK4-236

- 1
- 2
- 3
- 4

PTO2A

- A
- B
- C
- D

TERMINAL STRIP

- 1
- 2
- 3
- 4

A XLR-3

- 1
- 2
- 3

A XLR-3

- 1
- 2
- 3

- 5
- 6
- NONE

B XLR-3

- 1
- 2
- 3

B XLR 3

- 1
- 2
- 3

- 7
- 8
- NONE

PCN NO.

WARRANTY

VALIDYNE ENGINEERING CORPORATION warrants equipment of its own manufacture to be free from defects in material and workmanship under normal conditions of use and service.

VALIDYNE will rework or replace any defective item returned to VALIDYNE within its warranty period as specified below:

1. Pressure Transducers and Pressure Transmitters (including transducers supplied as part of Digital Manometer Systems) within three (3) years of its original purchase.
2. Electronics products (Transducer Indicators, Carrier Demodulators, plug-in Signal Conditioners, Module Cases, etc.) within one (1) year of its original purchase.
3. OEM Transducers within one (1) year of its original purchase.

Buyer is requested to secure authorization of VALIDYNE and to describe defect prior to return of equipment under warranty. Shipment to VALIDYNE shall be at Buyer's expense, with return at VALIDYNE's expense. NON-VERIFIED problems or malfunctions, whether warranty or not, are subject to an \$80.00 evaluation charge.

The warranty carries no liability, either expressed or implied, beyond our obligation to the original purchaser to rework or replace, at VALIDYNE's option, the unit which carries the warranty. Prices, specifications, and designs are subject to change without notice. This warranty is void if the product is subjected to misuse, accident, neglect, or improper application or operation.

Out of Warranty Rework

Units returned to VALIDYNE for rework which are out of warranty will be subject to the following conditions:

1. A description of the problem or malfunction shall accompany the unit returned for rework or be communicated to VALIDYNE prior to shipment. Otherwise there will be a minimum evaluation and/or calibration charge of \$80.00.
2. Unit will be reworked automatically if charge is less than 65% of current list price unless other specific instructions are received. Above 65% VALIDYNE will request authorization by Buyer.
3. If quotation is required before proceeding with rework, unit should be accompanied by a document so stating or information communicated to VALIDYNE prior to shipment. An \$80.00 evaluation charge will be invoiced for this service.
4. Buyer is to secure authorization and shipping method from VALIDYNE prior to return of equipment or shipment will be rejected. (Applies to Canada only)
5. Shipping charges in both directions are the responsibility of the Buyer for all out of warranty returns.

Warranty on Rework

Warranty coverage on rework is 90 days on work done or to the end of the original warranty period, whichever is longest.



8626 Wilbur Ave. • Northridge, CA 91324 • (818) 886-2057
AUTOMATIC FAX: (818) 886-6512 • TOLL FREE: (800) 423-5851